

# The Basics of Limit Switches

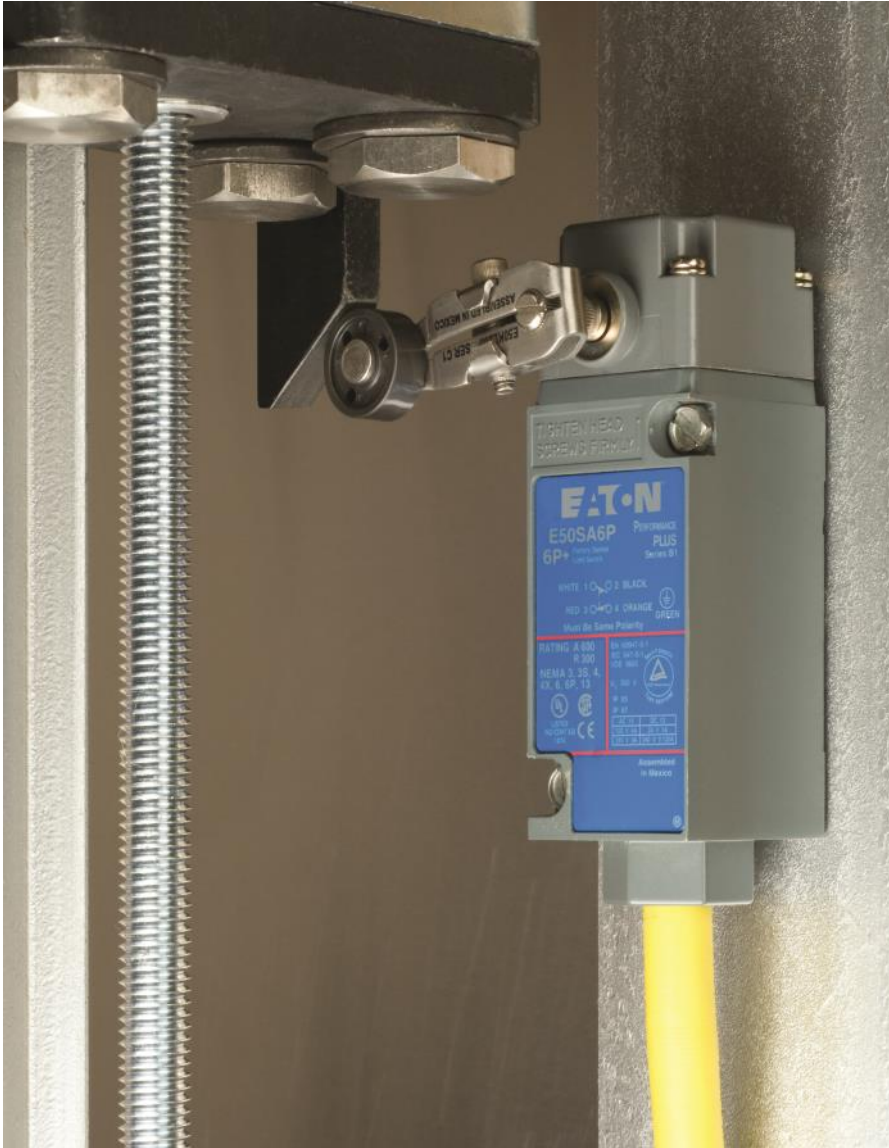

Powering Business Worldwide

---

# Table of Contents

---

Introduction.....	3-4
Typical Limit Switch Applications.....	3
Features and Benefits of Limit Switches.....	4
Limitations of Limit Switches.....	4
Limit Switch Terminology.....	4
Limit Switch Styles.....	5-7
Actuator/Operating Head.....	5
Switch Body.....	5
Receptacle/Terminals.....	5
Standard Industrial Oiltight.....	5
Precision.....	6
Actuators and Operating Heads.....	8-9
Rotary Lever Types.....	8
Typical Levers.....	8
Plunger Type Actuators.....	9
Electrical Outputs.....	10-12
Poles, Throws.....	10
Snap Action vs. Slow Make-Break.....	10
Electrical Ratings.....	10
Polarity Observations.....	11
Single Pole-Double Throw.....	11
Double Pole-Double Throw.....	12
Indicating Lights.....	12
Low Energy Loads.....	12
Receptacles.....	13-14
Surface Mount Type.....	13
Manifold Mounting Type.....	14
Side Mounting Type.....	14
Special Purpose Limit Switches.....	15-16
Neutral Position Switches.....	15
Two Step Switches.....	15
Gravity Return Switches.....	15
Guard Switches.....	16
Cam Design Considerations.....	17-18
Lever Arm Actuators.....	17
Plunger Type Actuators.....	18
Wobble Stick and Cat Whisker.....	18
Mounting Considerations.....	19
Appendix.....	20-22

# Introduction: Limit Switch Sensing

Presence Sensing is the act of detecting the presence or absence of an object with a contact or non-contact sensing device. The sensors then produce an electrical output signal that can be used to control equipment or processes.

Mechanical limit switches are contact sensing devices widely used for detecting the presence or position of objects in industrial applications. The term limit switch is derived from the operation of the device itself. As an object (or target) makes contact with the operator of the switch, it eventually moves the actuator to the "limit" where the electrical contacts change state.

Through this mechanical action, electrical contacts are either opened (in a normally closed circuit) or closed (in a normally open circuit). Inductive proximity, capacitive proximity, and photoelectric sensors perform this same process through non-contact sensing.

## Typical Limit Switch Applications

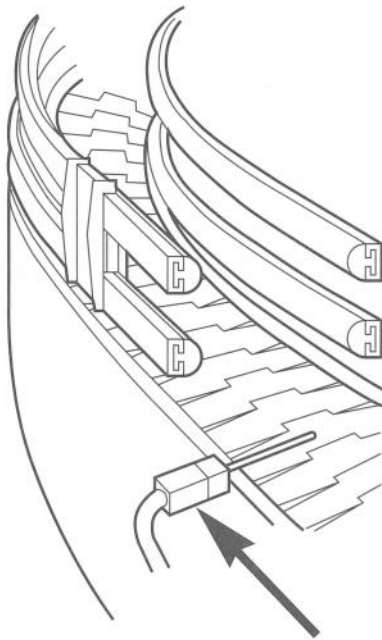

*Cat Whisker Limit Switch Used In Material Handling*

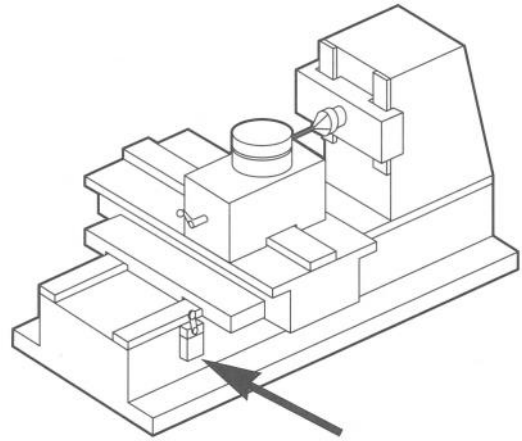

*Sealed Limit Switch Used In a Machine Tool*

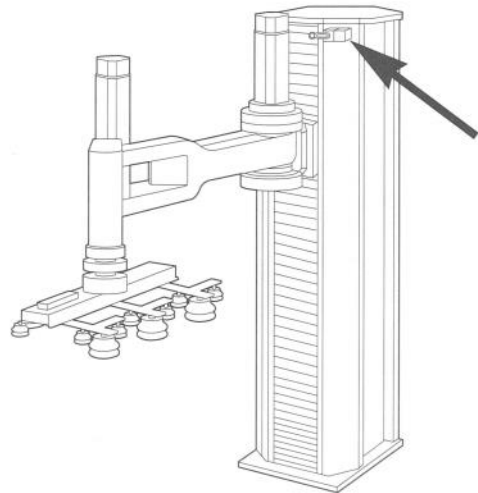

*Limit Switch Used to Indicate End of Travel On a Palletizer*

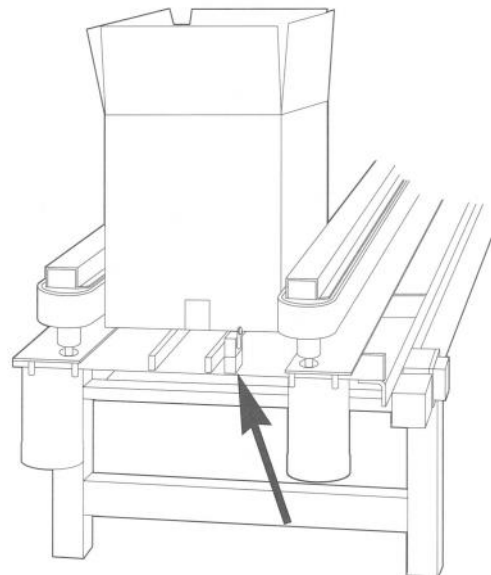

*Used for Positioning in a Fill Operation*

## Features and Benefits of Limit Switches

- Can be used in almost any industrial environment
- Very precise in terms of accuracy and repeatability
- Consume little electrical energy
- Can switch loads with high inductance
- Can control multiple loads

## Limitations of Limit Switches

- Generally restricted to equipment operating at relatively low speeds.
- Must make direct contact with target.
- Moving mechanical parts will wear out.

## Limit Switch Terminology

**Pretravel** — the distance or angle that the actuator must go through to trip the contacts

**Operating Point** — position of the actuator at which the contacts snap to the operated position

**Release Point** — the position of the actuator at which the contacts return to their original state

**Differential** — distance (degrees) between contacts trip and contacts reset

**Overtravel** — movement of the actuator beyond the contacts trip point

**Initial Position** — position of actuator when no external force is applied to the actuator

Some other important terms associated with limit switches:

**Operating force (torque)** — force required to move the actuating element

**Minimum return force (torque)** — minimum force required to return actuator to its initial position

**Total Travel** — the maximum allowable distance the actuating element can travel

**Repeat Accuracy** — ability of a switch to repeat its characteristics precisely from one operation to the next operation

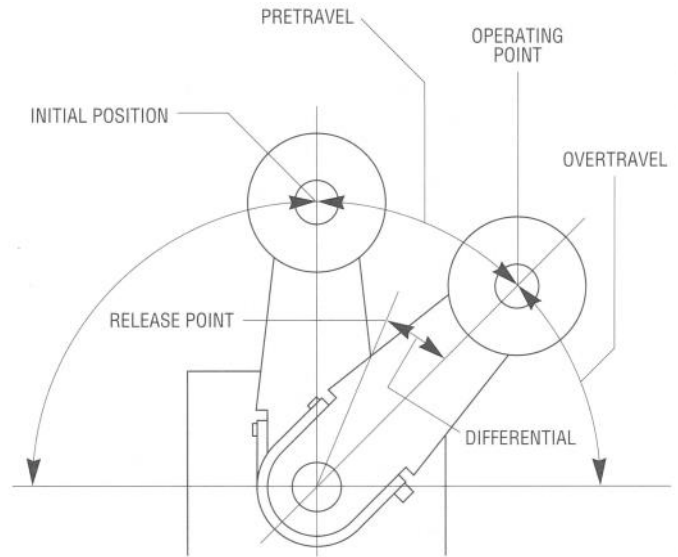

*Lever Type Actuator*

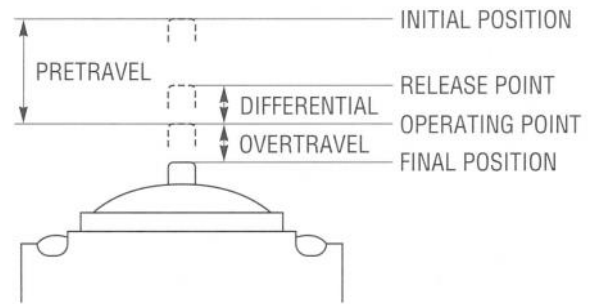

*Plunger Type Actuator*

# Limit Switch Styles

Most limit switches contain the following functional parts in one form or another.



## Actuator/Operating Head

The actuator is the part of the switch which physically comes in contact with the target. In some limit switches, the actuator is attached to an operating head which translates a rotary, linear, or perpendicular motion to open or close the electrical contacts of the switch.

## Switch Body

The component containing the electrical contact mechanism.

## Receptacle/Terminals

The component containing the terminal screws or screw/clamp assembly necessary for wiring purposes.

While there are a number of different styles of limit switches available in the market today, this manual will describe two classes of limit switches — standard industrial oiltight and precision switches.

### Standard Industrial Oiltight

The classification standard industrial oiltight represents those limit switches which are most often the first choice for industrial applications.

These switches are designed to function in a variety of industrial environments where oil, grease, dirt, high pressure washdown, shock or vibration are present. Typically these devices meet NEMA enclosure ratings of 1, 3, 3S, 4, 6, 11, 12, 13 and possibly more. Some version meet IEC ratings such as IP66, IP67, etc. Most manufacturers offer models suitable for applications from light to extremely harsh duty.

Standard industrial switches are available in two configurations, plug-in and non plug-in. For most manufacturers, plug-in, or modular limit switches, are represented as their heavy duty application switch. This

is due to the sensors having a long electrical and mechanical lifetime. These switches are designed so that the operating head, switch body and receptacle are separate components, as shown below.



*Plug-in Limit Switch*

Convenience is the advantage of the plug-in modular design. When installing a plug-in switch the user mounts the receptacle to the fixture or machine it is to be used on. The wiring is then brought into the receptacle through the conduit entrance on the bottom of the device. The wires are connected to the terminals in the receptacle.

The switch body then plugs-in to the receptacle and is secured with screws. The operating head is attached to the top of the witch body with screws as well.

The switch body can be quickly and easily replaced in the field without having to rewire the connections to the terminals in the receptacle. The majority of new industrial applications today utilize the plug-in design switch due to its superior sealing and ruggedness.

Non plug-in switches differ from plug-in switches in that the switch body and receptacle are one piece, as seen with the sensor below. The operating head is still a separate piece.



*Non Plug-in Limit Switch*

The wiring in a non plug-in switch is brought in through the conduit entrance at the bottom of the body/receptacle. The wiring terminals are accessible through the front of the switch by removing a cover plate. The cover plate is attached by two screws and contains a gasket on one side to provide a tight seal against the sensor.

Even though the non plug-in design is somewhat outdated most manufacturers still offer them. It is also a popular design for European DIN (Deutsch Industrie Norm) limit switches. DIN switches are built to meet dimensional and operational standards set in Europe.



*DIN Limit Switch*

This style switch typically has the same electrical contact and enclosure ratings as heavy duty switches, but their electrical or mechanical life is not as long. They are an economical alternative to heavy duty switches in applications where the switch is not subjected to physical abuse.

**Hazardous Location Switches** are another type of non plug-in limit switch.

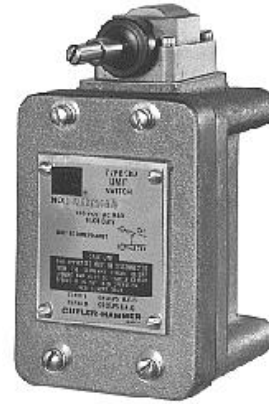

*Hazardous Location Limit Switch*

These switches are designed to contain an explosion within the switch itself. Hazardous location switches are usually provided with four mounting holes and the cover is secured, using four screws. This device is much heavier and thicker in construction than standard oiltight switches.

These sensors generally meet NEMA 1 requirements in addition to the hazardous location requirements of NEMA 7 Class I, Groups B, C and D as well as NEMA 9 Class II, Groups E,F and G. Some manufacturers do offer models rated NEMA 4X, 13 as well. Like standard oiltight switches, hazardous location switches have removable actuating heads which are attached to the switch body with four screws.

**Precision**

Precision switches are widely used in both commercial and industrial applications ranging from appliances to farm equipment. They are often chosen for their precise operating abilities, small size and low cost. Precision switches are typically available in two styles, basic precision and enclosed precision..

The basic precision switch is a one piece construction where the switch body, receptacle and actuator are all contained in one element.



*Basic Precision*

Enclosed precision switches consist of a two piece die cast housing. **Notes**



*Enclosed Precision*

The two piece construction is held together by two screws on the underside of the device. A gasket cover is placed in between the two pieces to provide a tight seal, keeping contaminants out of the device. The conduit is brought through the entrance on the top half of the device and is connected to either the screw or solder terminals.

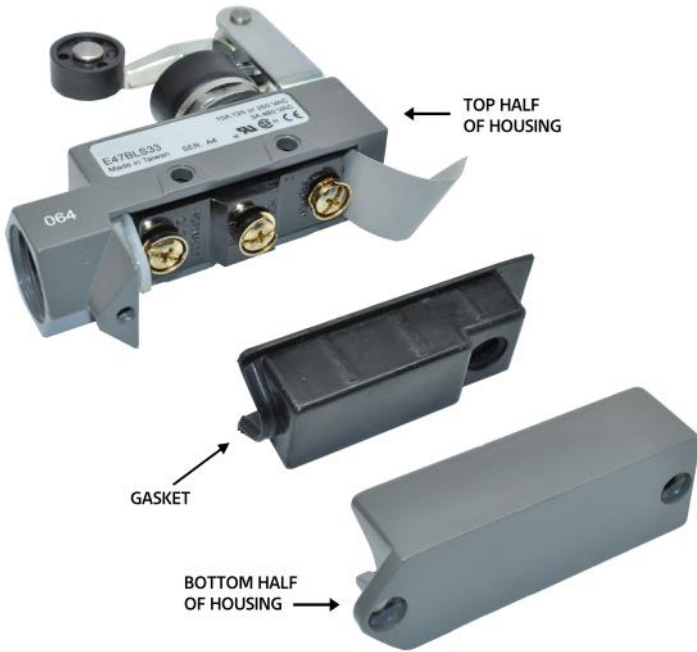

Basic precision switches are generally not given a NEMA enclosure rating, while some enclosed precision switches can be rated NEMA 4, 13.



# Actuators and Operating Heads

Choosing the proper actuator depends on the shape, speed, direction and total travel of the cam or machine part being used to trip the limit switch. The next several pages describe various types of actuators and when they are typically used.

Operating heads for standard oiltight switches are usually one of two types: momentary (also known as spring return) or maintained contact.

With momentary switches, the contacts return back to their normal state as soon as the actuator is released. In maintained switches, the contacts remain operated even after the actuator has been released. They are reset by some further mechanical action of the operating head. On rotary operating heads, the contacts are reset by rotation in the opposite direction. On plunger types, there are two plungers on opposite sides of the head. One sets and the other resets.

## Rotary Lever Types

Rotary lever types — with lever actuators, a cam or plate hits the end of the lever arm which in turn rotates a shaft and operates the con-tacts in the switch. The rotation may be spring returned (momentary) or maintained.

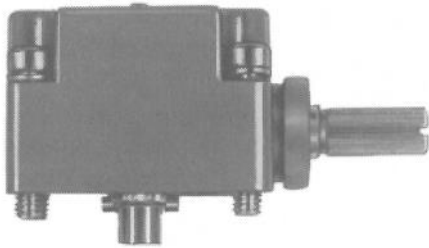

*Rotary Actuator Head*

The lever arms may be rod or roller types in various fixed or adjustable lengths, and made from various materials and sizes of rollers. Lever actuators are usually the best choice for the majority of applications and are suitable for actuation by any cam whose motion is perpendicular to the shaft axis about which the lever rotates. Selection of lever length should be based on the distance between switch mounting and cam.

## Typical Levers

**Standard roller** — used for most rotary lever applications. Available in various lengths. Roller typically made of nylatron.



**Ballbearing roller** — used where abrasive dusts would cause undue wear of standard nylatron rollers and also with high speed cams.



**Adjustable length** — used where the length of arm required is not known when devices are ordered.



**Forked** — used with maintained contact style switches. When rollers are on opposite sides one cam will trip the switch and a second will reset the switch. When rollers are on same side, one cam trips and resets the switch.



**Offset** — used to obtain different cam track dimensions.



**One way roller** — used with reversible cams where operation in one direction only is required.



**Rod or loop** — used where unusual shape is required. Rods are typically made of steel or nylon. Loops are made of nylatron.



**Spring rod** — used on conveyors where jams may occur. Flexible rod moves in any direction and eliminates damage to arm or switch.





## Plunger Type Actuators

Plunger types are the best choice where short controlled machine movements are present or where mounting space does not permit a lever type.



**Top push rod plunger** — actuation must be in line with plunger axis. Care should be taken to avoid exceeding the overtravel stated by the manufacturer. A mechanical stop should be used where the possibility of excessive overtravel exists

**Side push rod plunger** — should be used where the mounting permits operation from the side only and not from the top. As with the top push, avoid exceeding recommended overtravel. Available in both momentary and maintained styles.

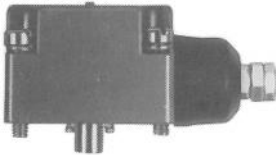

*Momentary*

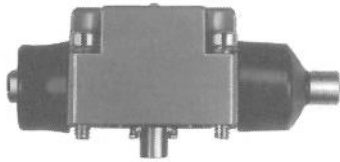

*Maintained*

**Top and side roller plunger** — function similar to push rod styles except there is a roller attached to the end of the rod. Typically used where a lever arm will not fit for lateral actuation. Roller can be positioned either vertically or horizontally.



*Side Roller Plunger*



*Top Roller Plunger*

It should be noted that many switch manufacturers do not recommend using plunger or rotary type actuators in applications where the switch is to be held in an actuated position for an extended period of time. This is primarily due to the material characteristics of the sealing gaskets and boots used in limit switch construction. When an operating head is held in an actuated position for extended periods of time, particularly at low temperatures, the materials may lose their elasticity and take a "set".

Plunger type actuators are also the primary means of actuating a precision switch as well. The method of depressing the plunger varies.

**Pin plunger** — most often used where extremely small differentials and operating forces are required.



**Straight plunger** — used where the actuating element travels in same axis as plunger. Available in standard and extended lengths.



**Lever plunger** — used in applications where the cam actuates in line with the plunger but may require a larger differential or where an appreciable side thrust is present.



**Roller lever plunger** — used in those applications where the cam will pass by the switch laterally.



**Roller plunger** — used in those applications where the cam may present some degree of side thrust.



Enclosed precision switches are for the most part available with the same styles of actuators as basic switches. Enclosed switches are available with or without a boot around the actuator to help seal the switch if necessary.



*Enclosed Switch Without Boot*



*Enclosed Switch With Boot*



*Operator Head For Use With Cat Whisker or Wobble Stick Operator*

**Cat whisker and wobble stick** actuators are typically used in conveying applications to count objects as they pass by. They can be actuated in any direction.

# Electrical Outputs

The choice of which output configuration to use is largely dependent upon what type and how many electrical loads the limit switch is to control. As stated earlier, the electrical requirements of the load may be the deciding factor in switch selection. There are some basic contact configurations which are common to most limit switches.

## Poles, Throws

Some of the terminology associated with output devices can be understood with the following definitions and diagrams.

**Pole** — the number of completely separate circuits that can pass current through the switch at any one time.

**Throw** — the number of different circuits that each pole can control.



*Single Pole-Single Throw  
1 N.O. Contact  
Form A*



*Single Pole-Single Throw  
1 N.C. Contact  
Form B*



*Single Pole-Double Throw  
1 N.O.-1 N.C. Contacts  
Form C*



*Single Pole-Double Throw  
1 N.O.-1 N.C. Contacts  
Form Z*

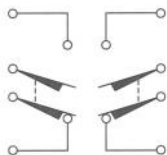

*Double Pole-Double Throw  
2 N.O.-2 N.C. Contacts  
Form Z*

By looking at the diagrams it can be seen that in the case of a double pole switch, current can be carried to two separate circuits at any one time. In a single pole switch only one circuit can have current to it any one time. Likewise it can be seen that a single throw switch controls only one circuit while a double throw controls two.

## Snap Action vs. Slow Make-Break

Most limit switches use one of two methods for contact action. The most common method is snap action. This involves a rapid motion of contacts when changing between closed and open states. Only small amounts of force are required from the actuator to initiate snap action.

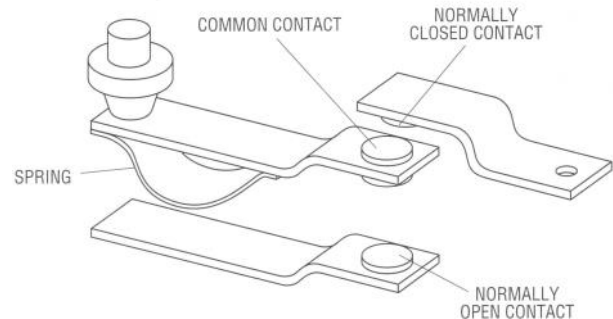

In a snap action switch, as the plunger (actuator) is depressed it reaches the operating point. At this point the common contact accelerates away from its free position with the normally closed contact and towards the normally open contact. This acceleration is caused by the spring mechanism of the switch and is independent of further movement of the actuator. Now the normally open switch is closed and the normally closed switch is open.

When the actuating force is removed from the plunger it travels upward until it reaches the release point. At this point the spring now accelerates the common contact away from the normally open contact and towards the normally closed contact. Even though the plunger will continue upwards to its free position, any further contact action will be independent of this. Now the normally open contact is open again and the normally closed is closed again.

There is an important variation on the snap action switch known as a **positive opening switch**. While this device still uses snap action contacts, it goes a step further by using non-resilient members to achieve contact separation. In other words, separation of the switches' N.C. contacts is achieved through a device other than a spring when the switch is actuated so that under light contact sticking conditions the weld is broken.

**Slow make and break contacts** are moved directly by the operating shaft; there is no spring mechanism. The contacts open and close at the speed of the actuator. This type is typically only used where the movement of the actuator must break welded contacts.

## Electrical Ratings

Electrical ratings are generally described in two ways.

1. Inductive
2. Resistive

**Inductive Rating** — indicates the inductive load from devices such as starters, contactors, solenoid and relay coils that the contacts can make or break. Inductive ratings typically have three components:

**Make** — load that the switch can handle when contacts close. This is associated with inrush currents and is a short duration rating, typically two cycles.

**Break** — load that the switch can handle when the contacts open. In most cases this should be considered the maximum continuous switch current.

**Continuous** — load that the switch can handle without making or breaking the load.

**Resistive Rating** — Resistive loads only that the contacts can make or break.

For AC control circuits inductive ratings are less than the continuous or resistive ratings. When the contacts break an inductive circuit, the current in the circuit has a tendency to continue in the same direction due to the inductance of the load. An arc will then occur across the contacts which will tend to heat and burn them. Therefore in order to compensate for the extra heat and wear, the maximum allowable inductive current is always less than the resistive current to achieve equal contact life.

For AC inductive loads the make current is often 10 times the break current. This is due to the fact that inductive coil loads often have inrush currents that are ten times the sealed (break) current.

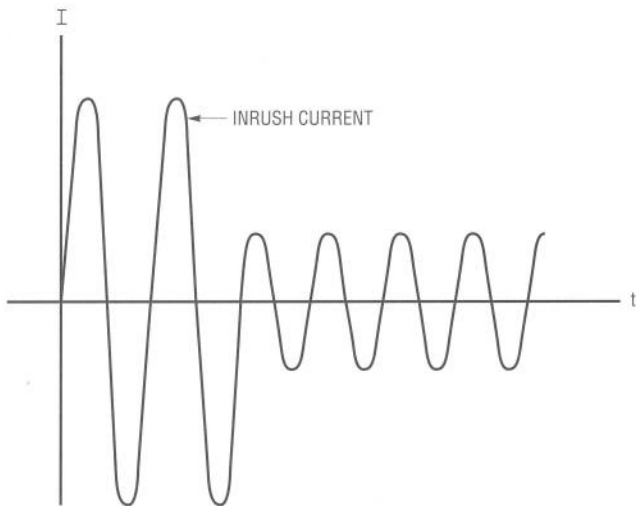

The duration of the inrush current is very short, typically 30 ms or less. The contacts of the switch must also be able to break this inrush current in an emergency.

For both AC and DC control circuitry applications, most circumstances require that the contacts of control circuit devices be applied at values less than their maximum make and break ratings. This is in order to provide a margin of safety, extend the electrical life and reduce the chance of contact welding.

**Polarity Observations**

Polarity is a term which is used to describe the relationship between the load and line connections in a multicircuit switch. Take a set of contacts with terminals that are made electrically common. If a line to line short circuit does not occur, these contacts are said to be connected to the same polarity. If a line to line short circuit does occur the contacts are said to be of opposite polarity.

Some limit switches have their sets of contacts isolated from each other on the same pole. They are said to have electrically isolated outputs and are labeled as such.

Most devices, however, do not have isolated sets of contacts on the same pole and care must be taken to observe polarity. Failure to do so can cause permanent damage to the switch, the wiring or both.

Following are some examples of the correct and incorrect ways to wire contacts with regard to polarity.

**Single Pole-Double Throw**

**Correct::**

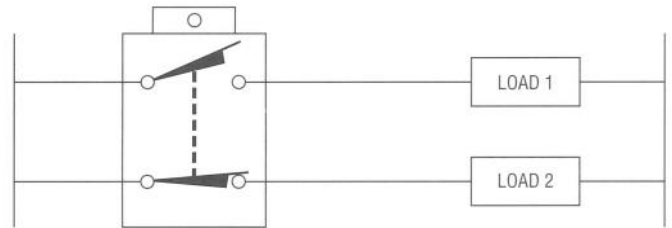

1. Contacts connected to same polarity.
2. Contacts change state, an arc occurs.

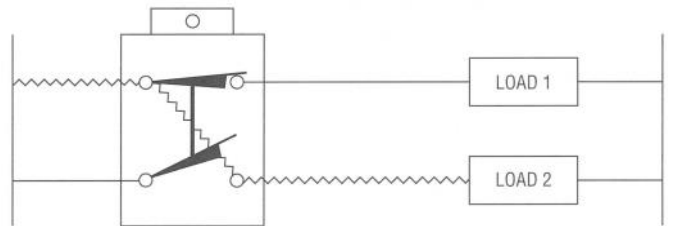

3. Arc cannot cause line to line short.

**Incorrect::**

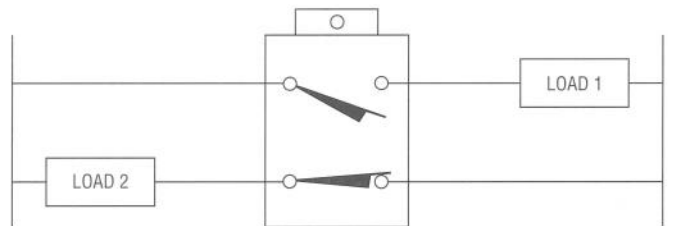

1. Contacts connected to opposite polarities.
2. Contacts change state, an arc occurs.

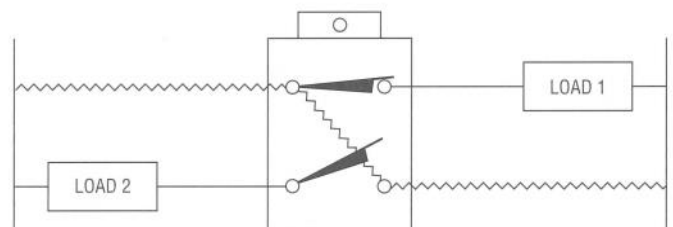

3. **DO NOT** wire contacts this way. Arc can cause line to line short.

Power from different sources should not be connected across the two sets of contacts in a single pole switch.

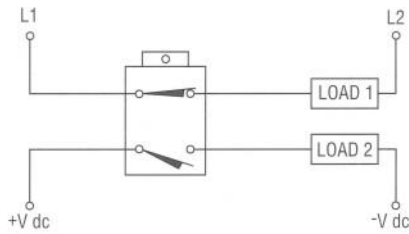

## Double Pole-Double Throw

With double pole-double throw limit switches, if each pole is electrically separate, then they may be used on opposite polarities. However polarity must still be observed within each pole.

Power from different sources may also be used with double pole switches so long as each pole is electrically separate from the other.

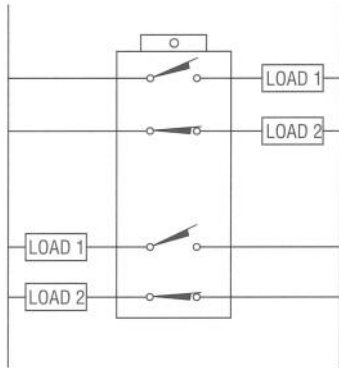

## Indicating Lights

Most manufacturers of plug-in style limit switches offer switch bodies which have an indicating light.

The indicating light allows the limit switch user to see at a glance

what the status of the switch output is. The lights are usually either a 24-120 VAC/DC LED or a 120 VAC neon lamp. The load being switched should meet the voltage requirements of the light in order to insure the light functions.

The indicating lights can be wired to turn on when either the normally open or the normally closed contacts change state.



INDICATING LIGHT

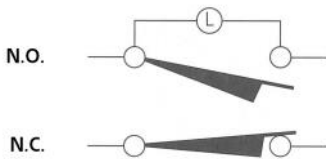

Light On When N.C. Contact is Closed

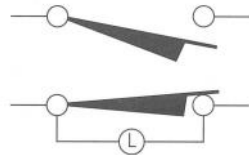

Light On When N.O. Contact is Closed

There is a leakage current flowing through the switch via the light even when the contacts of the switch are open and the light is off. This can present a problem to certain high impedance loads such as PLCs. This problem can be taken care of by placing a resistor in parallel with the load to "bleed" off this leakage current.

## Low Energy Loads

Limit Switch manufacturers are often asked if their switches are PLC compatible. This is really begging the question of how the switch performs with low voltage, low current DC or AC loads (low energy). The reason for this concern is that under normal operation, metal contacts have a tendency to become contaminated by oxide films which form on the surface of the contacts, and by particles of dust and other matter. When a switch is being used to control an inductive load the associated inrush currents and arcing will burn off any contaminants present. With low energy loads the possibility exists that contaminants will not be burned away and eventually discontinuity can occur.

Another concern with limit switches and PLC's is the phenomena of contact bounce. When a set of mechanical contacts close they have tendency to strike each other more than once or bounce. A PLC with a fast scan time can read this as a multiple count or input. There are steps that can be taken in the design of limit switches which can minimize both contact contamination and contact bounce. Most manufacturers of limit switches can provide performance data on their switches and can recommend which one to choose.

# Receptacles

## Surface Mount Type

This is the most common and simplest style of mounting. It is available in both plug-in and non plug-in style switches. Typically only two holes need to be drilled in order to mount the switch, although in the case of hazardous location switches, four are often used.

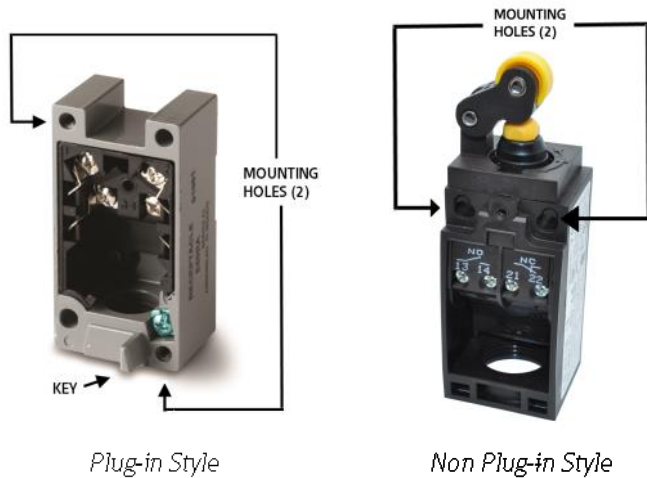

Wiring is done through the conduit entrance in the bottom of the switch and the wires are connected to captive type screw terminals in the receptacle.

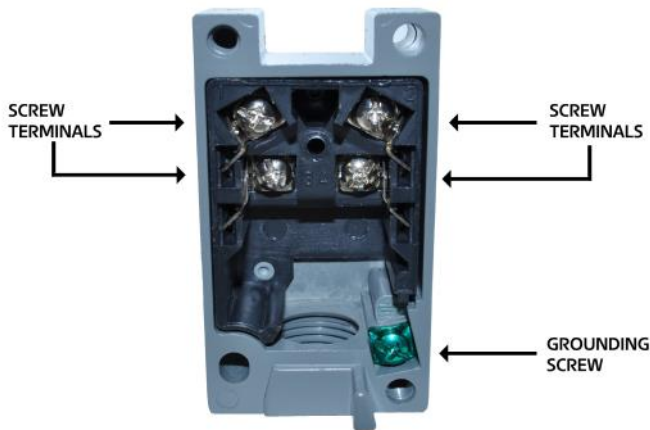

In single pole-double throw switches there are typically five screw terminals in the receptacle. Four of these are for connecting the loads and the fifth is a grounding terminal. Some limit switches may have insulated housings and not require a ground connection.

The receptacle is wired according to the diagram found either on the switch body, in the case of a plug-in style, or on the cover plate, in a non plug-in style.

In the receptacle for double pole-double throw switches there are nine screw terminals, four more than the single pole receptacle.

Most manufacturers key their receptacles on plug-in units such that a single pole receptacle will accept only a single pole switch body and likewise for double pole.

A popular variation offered by some manufacturers is to prewire the receptacle at the factory and then epoxy fill the cavity. This process helps ensure environmental sealing. These devices are typically available with either a specified length of cable or a pin connector threaded into the conduit hole.



*Epoxy-filled Receptacle*



*Unitized Limit Switch*

The "superwet" cutting fluids used in the machine tool and automotive industry have led manufacturers to go beyond the epoxy filled receptacle. These switches are known as "unitized" switches because the receptacle and switch body are one piece, virtually eliminating the possibility of ingress between the switch body and receptacle. These units are also completely epoxy sealed internally.

## Manifold Mounting Type

---



In some applications it is desirable to bring the wiring into the limit switch through the back. This is usually the case if the installer is running the wire to the limit switch through a trough or wireway. Most manufacturers provide a gasket around the entrance to pre-vent leakage into the switch.

*Manifold Mounting  
Receptacle*

## Side Mounting Type

---

Side mounting is usually associated with basic precision style limit switches. The switch body/receptacle is one piece and the wiring connections are made to either screw or solder terminals on the under-side of the switch. Mounting holes are provided through the side of the switch body.



*Side Mounting Type  
Screw Terminals*



*Side Mounting Type  
Solder Terminals*

## Notes

---



# Special Purpose Limit Switches

Occasionally the need arises for a limit switch that can perform a unique or special function, such as detecting which direction an object is moving or its height, width and length. Most limit switch manufacturers offer some version of the following specialty limit switches.

## Neutral Position Switches

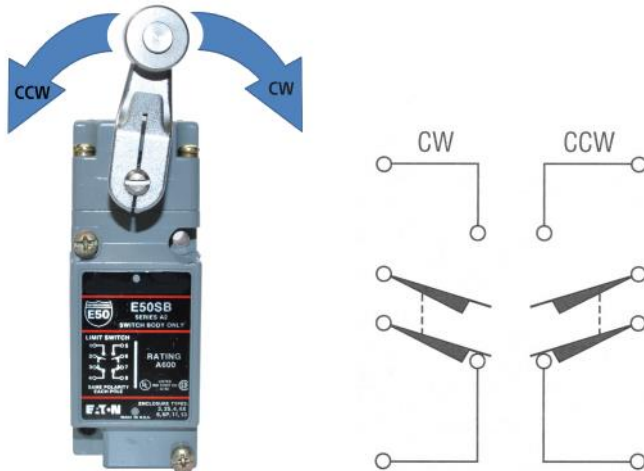

Neutral position switches have a double pole-double throw contact configuration. In this switch one set (pole) of contacts is actuated when the lever is actuated in one direction and the other set of contacts is actuated when the lever is actuated in the other direction. With this limit switch, direction of operation can be detected.

## Two Step Switches

Like the neutral position switch, the two step switch has a double pole-double throw contact configuration. The two step limit switch operates on the principle that rotating its lever operator 10 degrees actuates one set of contacts and moving the lever operator 20 degrees (in same direction) actuates the second set of contacts. With this switch, physical attributes of the object (height, orientation, position, completeness of assembly) can be determined and subsequent segregation or control automatically provided by one limit switch.

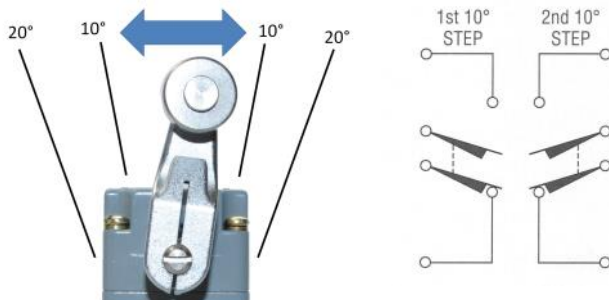

The two step switch can be selected to operate in the clockwise, counter-clockwise or both directions.

## Gravity Return Switches

Unlike most other side rotary limit switches, gravity return limit switches have no spring return mechanism. The weight of the operating lever must provide the force to return it to its free position. Gravity return switches are usually mounted with the operating head upside down and are typically available in single pole-double throw contact configurations.

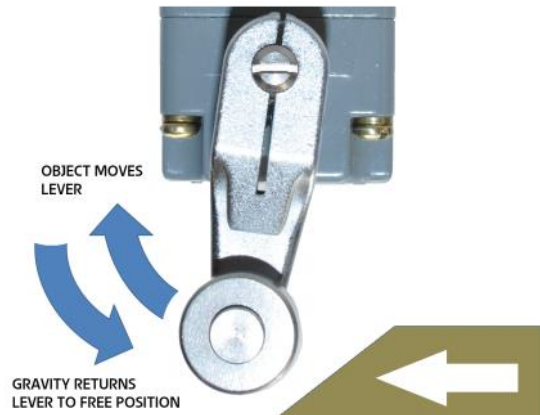



## Guard Switches

---

Often the need arises for a device to provide a signal indicating that a door has been closed or that a machine guard is in place before a machine can be turned on or a sequence of operations can begin. While a standard limit switch would probably be able to do this function, the unit could be false tripped or false actuated either accidentally or deliberately, posing a danger to the operator.

In response to this problem many limit switch manufacturers offer what is known as a keyed interlock switch. These switches look and operate similar to standard oiltight limit switches except for the operating heads. Instead of a rotary or plunger operating head there is a key and slot.



Actuation of the limit switch occurs only when the corresponding key is inserted into the key slot. The key is usually mounted on a door or machine guard in such a way that when door or guard is closed the key fits into the slot actuating the limit switch.

## Notes

---

# Cam Design Considerations

An important aspect of limit switch applications is cam design. Improper cam selection or design can lead to switch failure.

## Lever Arm Actuators

In order to maximize the life of the limit switch there are several general rules to follow. Which one to choose depends on the speed and style of the cam.

For lever arm actuators it is always desirable to have the cam force perpendicular to the lever arm. More plainly stated, the cam angle should equal the lever angle.

For applications in which the cam is travelling at speeds less than 50 feet/min. the design shown in the figure below is suitable.

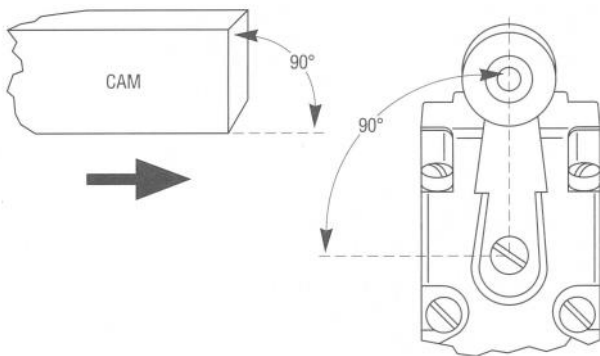

Those applications where the cam speed will be between 50-100 feet/min should have a cam angle and a lever angle of 45° as shown below.

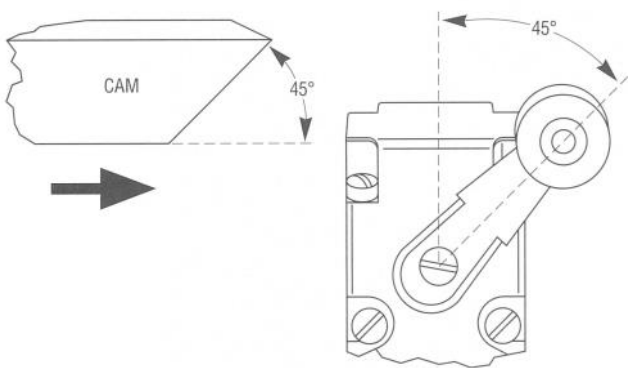

Both of these designs are for non overriding cams, that is cams which will not overtravel the actuating mechanism. For overriding cam applications the following design considerations should be followed for cam speeds up to 90 feet/min.

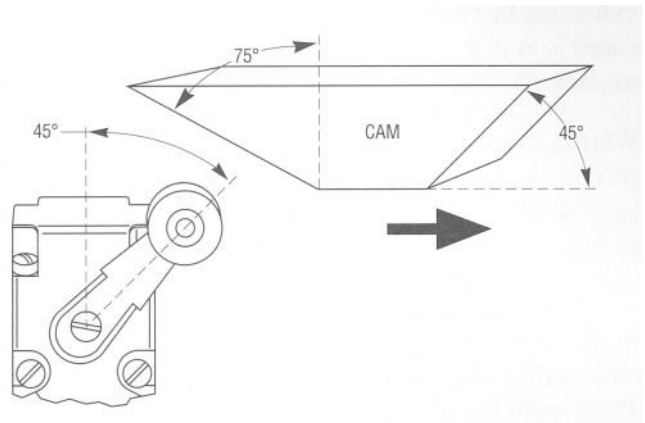

In overriding cam applications it is necessary to angle the trailing edge of the cam in order to prevent the lever arm from snapping back, which can cause shock loads which will reduce the life of the limit switch.

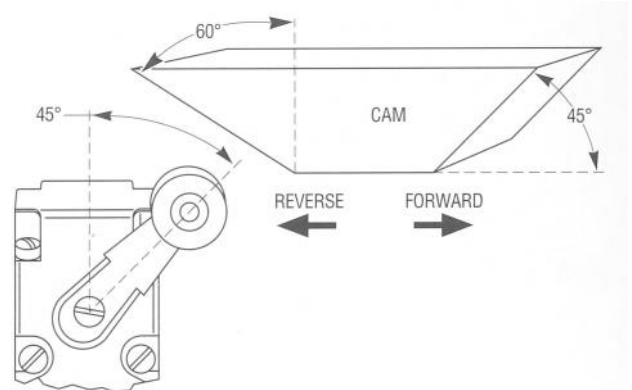

Some applications will require the cam to travel both forward and backward. In these instances it is necessary to change the trailing edge cam angle to 60° (from 75°).

For high speed cam applications it is recommended that the user consult the limit switch manufacturer for cam design tips.

## Plunger Type Actuators

---

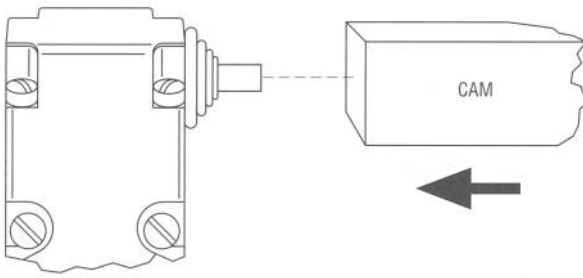

When using side push and top push plunger actuators the cam should operate in line with the push-rod axis as shown above.

Consideration should be given so as not to exceed the overtravel specifications of the device. Also the limit switch body should never be used as a mechanical stop for the cam.

When top roller plunger type actuators are being used the diagram below can be followed.

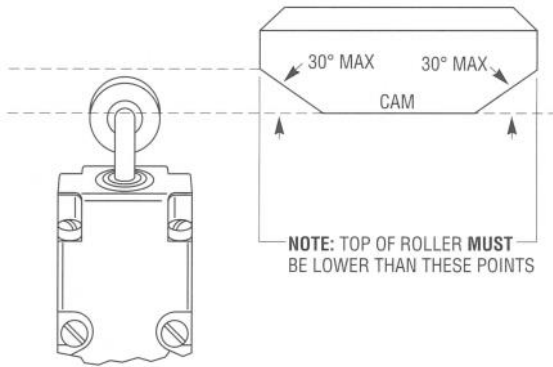

This design is suitable for applications with cam speeds of 140 feet/min or less.

For side roller plunger type actuators the design shown below can be used for cam speeds up to 90 feet/min.

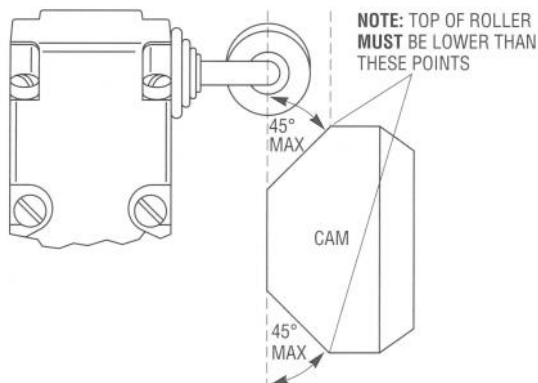

## Wobble Stick and Cat Whisker

---

When using these types of actuators, cam design is not critical and in most cases the actuating is being done by cartons, packages, bottles and such on a conveying line. As is the case with lever type actuators, care should be taken to avoid excessive snap back of the wobble stick or cat whisker.

## Notes

---

# Mounting Considerations

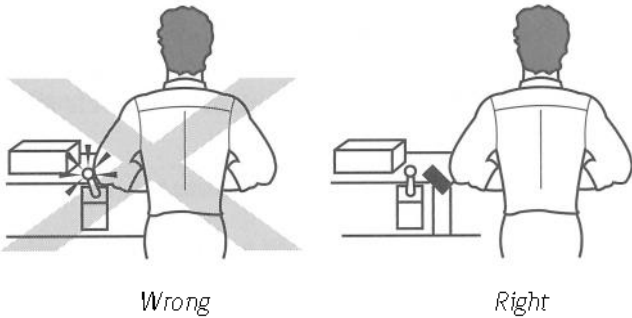

Limit switches should be mounted in locations which will prevent false operations by normal movements of operator or machine components.

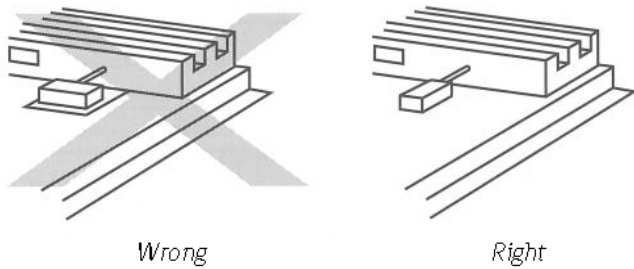

Limit switches should be mounted rigidly and in readily accessible locations, with suitable clearances to permit easy service and replacement when necessary. Cover plates should face maintenance access point.

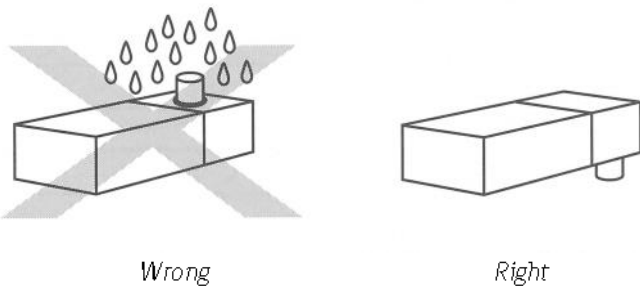

If liquid intrusion is a possibility, limit switches should be mounted face down. The force of gravity will help prevent liquids from entering seals on operating head. If such mounting does not provide solution the user should investigate submersible duty limit switches.

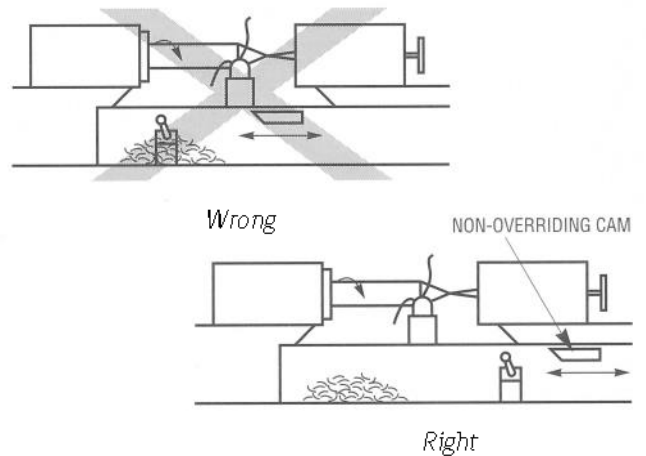

Limit switches should be placed in locations where machining chips do not accumulate under normal operating conditions.

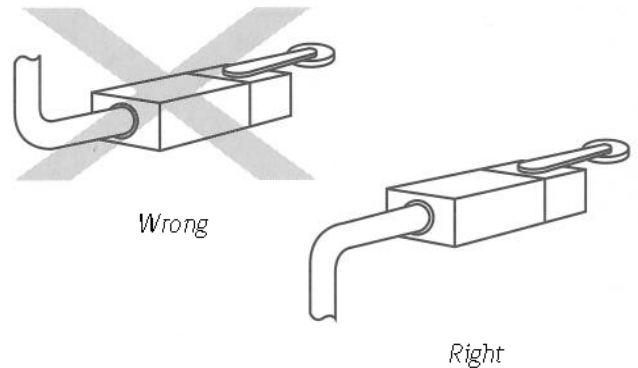

Liquids sometime reach the interior of limit switches by way of conduit connections either by seepage into conduit junctions or by condensation. All connection points exposed to fluids should be tightly sealed and switches should not be located at the low point of long conduit runs.

# Appendix

## Enclosure Ratings

### Index of Enclosure Protection — General

The UL, NEMA and IEC organizations (and other international groups) define degrees of protection provided by electrical enclosures with respect to personnel, equipment within the housing and the ingress of water.

Subtle differences do exist between the test procedures and specifications of these organizations.

To claim ratings to NEMA specifications, the testing is performed and certified by the manufacturers themselves.

To comply to UL and IEC specifications, the manufacturers must submit product samples, materials used and other data to an independent testing laboratory before ratings can be claimed.

In addition, IECC “IP” ratings differ from NEMA in that they do not apply to protection against the risk of explosion of conditions such as humidity, corrosive gases, fungi or vermin. In addition, different parts of the equipment can have different degrees of protection and still comply.

The table shown below is a comparison of the NEMA/UL/IEC enclosure specifications to be used as an approximate reference only. Do not use the table to convert from IEC to NEMA designations. For a definition of the ratings listed, see examples below and tables on **Page V8-A2-2**.

### NEMA/UL/IEC Enclosure Type Cross-Reference

#### Enclosure Type Cross Reference — Approximate

Note: IEC 529 does not specify equivalents to NEMA Enclosure Types 7, 8, 9 or 10.

NEMA Enclosure Rating	IP10	IP20	IP21	IP22	IP23	IP30	IP31	IP32	IP33	IP40	IP41	IP42	IP43	IP50	IP51	IP52	IP53	IP54	IP55	IP56	IP60	IP61	IP62	IP63	IP64	IP65	IP66	IP67	IP68
1	X	X	X	X	X	—	—	—	—	—	—	—	—	—	—	—	—	—	—	—	—	—	—	—	—	—	—	—	
2	X	X	X	X	X	—	—	—	—	—	—	—	—	—	—	—	—	—	—	—	—	—	—	—	—	—	—	—	
3	X	X	X	X	X	X	X	X	X	X	X	X	X	X	X	X	X	X	X	X	X	X	X	X	X	—	—	—	—
3R	X	X	X	X	X	X	X	—	—	—	—	—	—	—	—	—	—	—	—	—	—	—	—	—	—	—	—	—	
3S	X	X	X	X	X	X	X	X	X	X	X	X	X	X	X	X	X	X	X	X	X	X	X	X	X	—	—	—	—
4	X	X	X	X	X	X	X	X	X	X	X	X	X	X	X	X	X	X	X	X	X	X	X	X	X	X	X	—	—
4X	X	X	X	X	X	X	X	X	X	X	X	X	X	X	X	X	X	X	X	X	X	X	X	X	X	X	X	—	—
6	X	X	X	X	X	X	X	X	X	X	X	X	X	X	X	X	X	X	X	X	X	X	X	X	X	X	X	X	—
6P	X	X	X	X	X	X	X	X	X	X	X	X	X	X	X	X	X	X	X	X	X	X	X	X	X	X	X	X	X
12	X	X	X	X	X	X	X	X	X	X	X	X	X	X	X	X	X	X	X	X	X	X	X	X	X	X	—	—	—
13	X	X	X	X	X	X	X	X	X	X	X	X	X	X	X	X	X	X	X	X	X	X	X	X	X	X	—	—	—

# IEC Environmental Enclosure Ratings

## Example of Designations

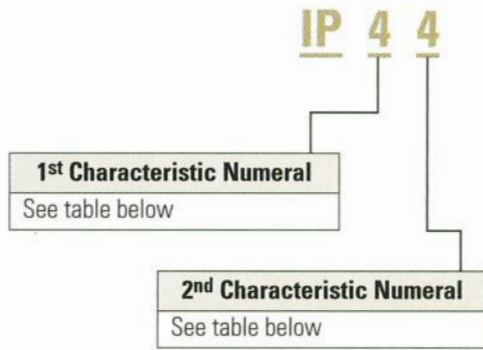

An enclosure with designation IP44 is protected against the penetrations of solid objects greater than 1.0 mm and against splashing water.

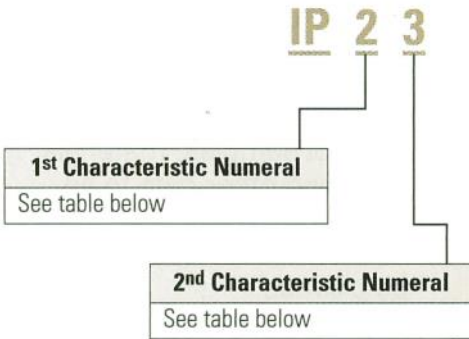

An enclosure with designation IP23 is protected against the penetration of solid objects greater than 12 mm and against rain.

## Index of Enclosure Ratings — IEC

### 1st Characteristic Numeral

Numeral	Description
<b>Protection against contact and the penetration of solid bodies</b>	
0	Not protected
1	Protection against solid objects greater than 50 mm
2	Protection against solid objects greater than 12 mm
3	Protection against solid objects greater than 2.5 mm
4	Protection against solid objects greater than 1.0 mm
5	Dust Protected
6	Dust-tight

### 2nd Characteristic Numeral

Numeral	Description
0	Not protected
1	Protection against dripping water
2	Protection against dripping water when tilted up 15°
3	Protection against rain
4	Protection against splashing water
5	Protection against water jets
6	Protection against heavy seas
6k	Protection against heavy seas with increased pressure
7	Protection against the effects of immersion
8	Protection against immersion
9k	High temperature water jets

## NEMA Definitions Pertaining to Non-hazardous Locations — NEMA Standard 250

**Type 1** — Enclosures are intended for indoor use, primarily to provide a degree of protection against contact with the enclosed equipment.

**Type 3** — Enclosures are intended for indoor use, primarily to provide a degree of protection against windblown dust, rain, sleet and external ice formation.

**Type 3R** — Enclosures are intended for outdoor use, primarily to provide a degree of protection against falling rain, sleet and external ice formation.

**Type 4** — Enclosures are intended for indoor or outdoor use, primarily to provide against windblown dust and rain, splashing water and hose-directed water.

**Type 4X** — Enclosures are intended for indoor or outdoor use, primarily to provide a degree of protection against corrosion, windblown dust and rain, splashing water and hose-directed water.

**Type 6** — Enclosures are intended for indoor or outdoor use, primarily to provide a degree of protection against the entry of water during occasional temporary submersion at a limited depth.

**Type 6P** — Enclosures are intended for indoor or outdoor use, primarily to provide a degree of protection against the entry of water during prolonged submersion at a limited depth.

**Type 12** — Enclosures are intended for indoor use, primarily to provide a degree of protection against dust, falling dirt and dripping non-corrosive liquids.

**Type 13** — Enclosures are intended for indoor use, primarily to provide a degree of protection against dust, spraying of water, oil and non-corrosive coolant.

**NEMA Definitions Pertaining to Non-hazardous Locations  
— NEMA Standard 250**

---

**Type 1** — Enclosures are intended for indoor use, primarily to provide a degree of protection against contact with the enclosed equipment.

**Type 3** — Enclosures are intended for indoor use, primarily to provide a degree of protection against windblown dust, rain, sleet and external ice formation.

**Type 3R** — Enclosures are intended for outdoor use, primarily to provide a degree of protection against falling rain, sleet and external ice formation.

**Type 4** — Enclosures are intended for indoor or outdoor use, primarily to provide against windblown dust and rain, splashing water and hose-directed water.

**Type 4X** — Enclosures are intended for indoor or outdoor use, primarily to provide a degree of protection against corrosion, windblown dust and rain, splashing water and hose-directed water.

**Type 6** — Enclosures are intended for indoor or outdoor use, primarily to provide a degree of protection against the entry of water during occasional temporary submersion at a limited depth.

**Type 6P** — Enclosures are intended for indoor or outdoor use, primarily to provide a degree of protection against the entry of water during prolonged submersion at a limited depth.

**Type 12** — Enclosures are intended for indoor use, primarily to provide a degree of protection against dust, falling dirt and dripping non-corrosive liquids.

**Type 13** — Enclosures are intended for indoor use, primarily to provide a degree of protection against dust, spraying of water, oil and non-corrosive coolant.

**NEMA Definitions Pertaining to Hazardous Locations —  
NEMA Standard 250**

---

E51 Limit Switch Type Proximity Sensors are rated for use in the following locations:

**Class I Division 2, Groups A, B, C or D — Indoor Use**

For the definition of a Class I Division 2 location, see the National Electrical Code Article 500-5, paragraph (b).

For the definition of a Class I Group A, B, C, D Classifications, see the National Electrical Code Article 500-3, paragraph (a).

**Class II Division 2, Groups F or G — Indoor Use**

For the definition of a Class II Division 2 location, see the National Electrical Code Article 500-6 paragraph (b)

For the definition of a Class II Group F and G Classifications, see the National Electrical Code Article 500-3 paragraph (b).

**Class III Division 2 — Indoor Use**

For the definition of a Class III Division 2 location, see the National Electrical Code Article 500-7 paragraph (b).

For the definitions of Class III Classifications, see the National Electrical Code Article 500-7.

**Notes**

---



For more  
information, call  
1-800-426-9184

